

Rapid channel Aluminium

Stylish & cost effective channel installation solution – simply position glass and grout in

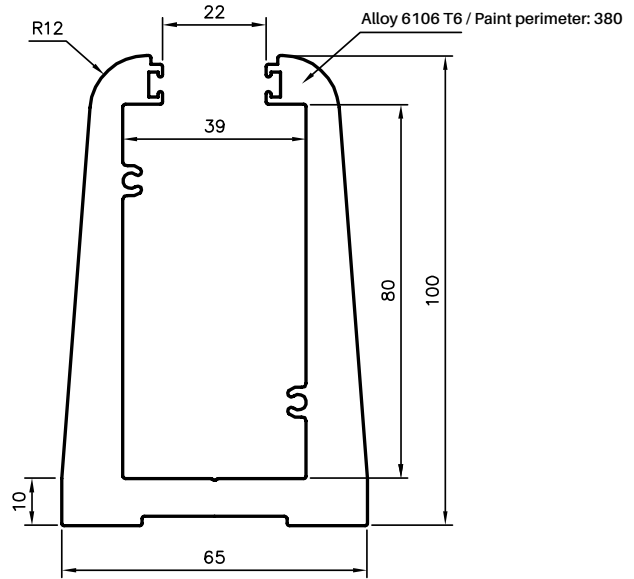

Rapid channel

4200MM LONG

Mill finish aluminium

Order Code: [RAP-4200-CH-M](#)

Advantages

- Surface mount grout in system
- Mill finish aluminium can be easily powder coated to any colour finish
- Suits up to 19mm thick glass
- Pool fencing and balustrade compliant
Contact us for load test reports
- Drill fixing holes as required through bottom of Rapid channel
- Quick and easy to mitre cut for internal or external corners
- Glazing wedge rubbers conceal grout for neat finish
- End caps and infill available for a complete install solution

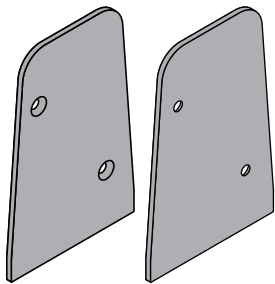
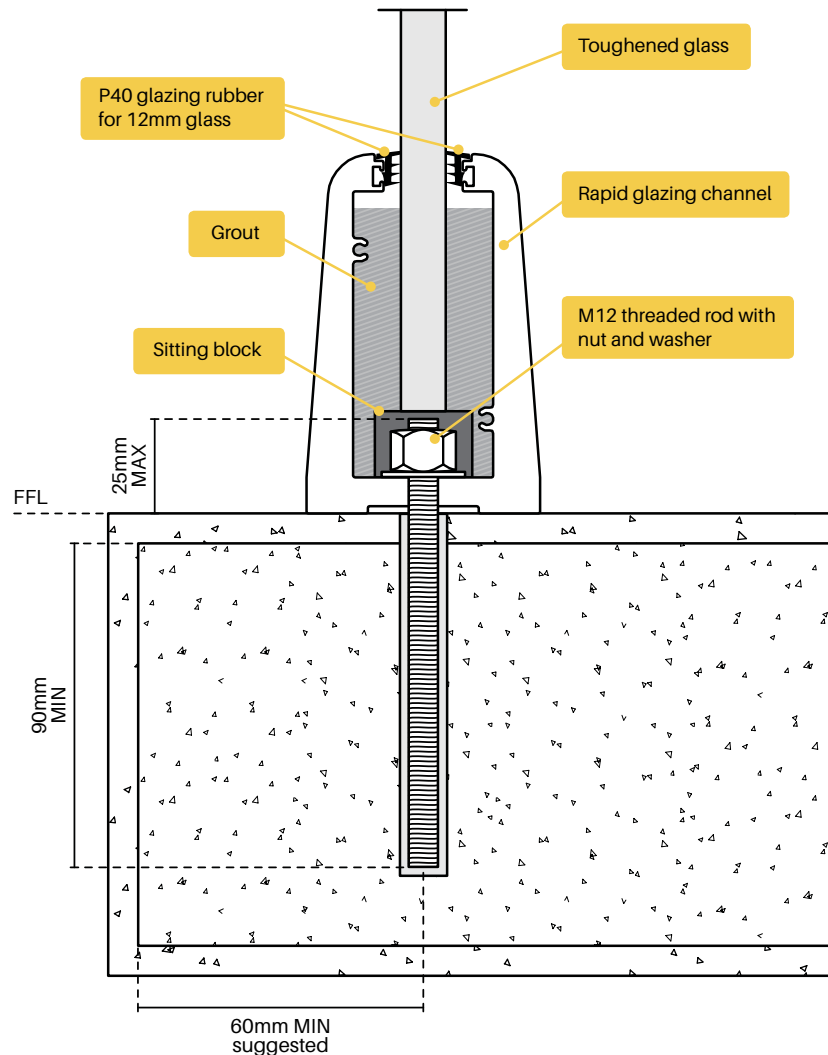

End plates

Order Code: [RAP-2EP-M](#)

- Mill finish aluminium
- Countersunk holes line up with screw flutes in channel
- 1x left & 1x right end plate included

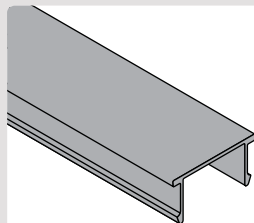

Channel infill

Order Code: [RAP-4200-INF-M](#)

- Mill finish aluminium - 4200mm long
- Snap-in infill between glass panels

Rapid Channel Aluminium

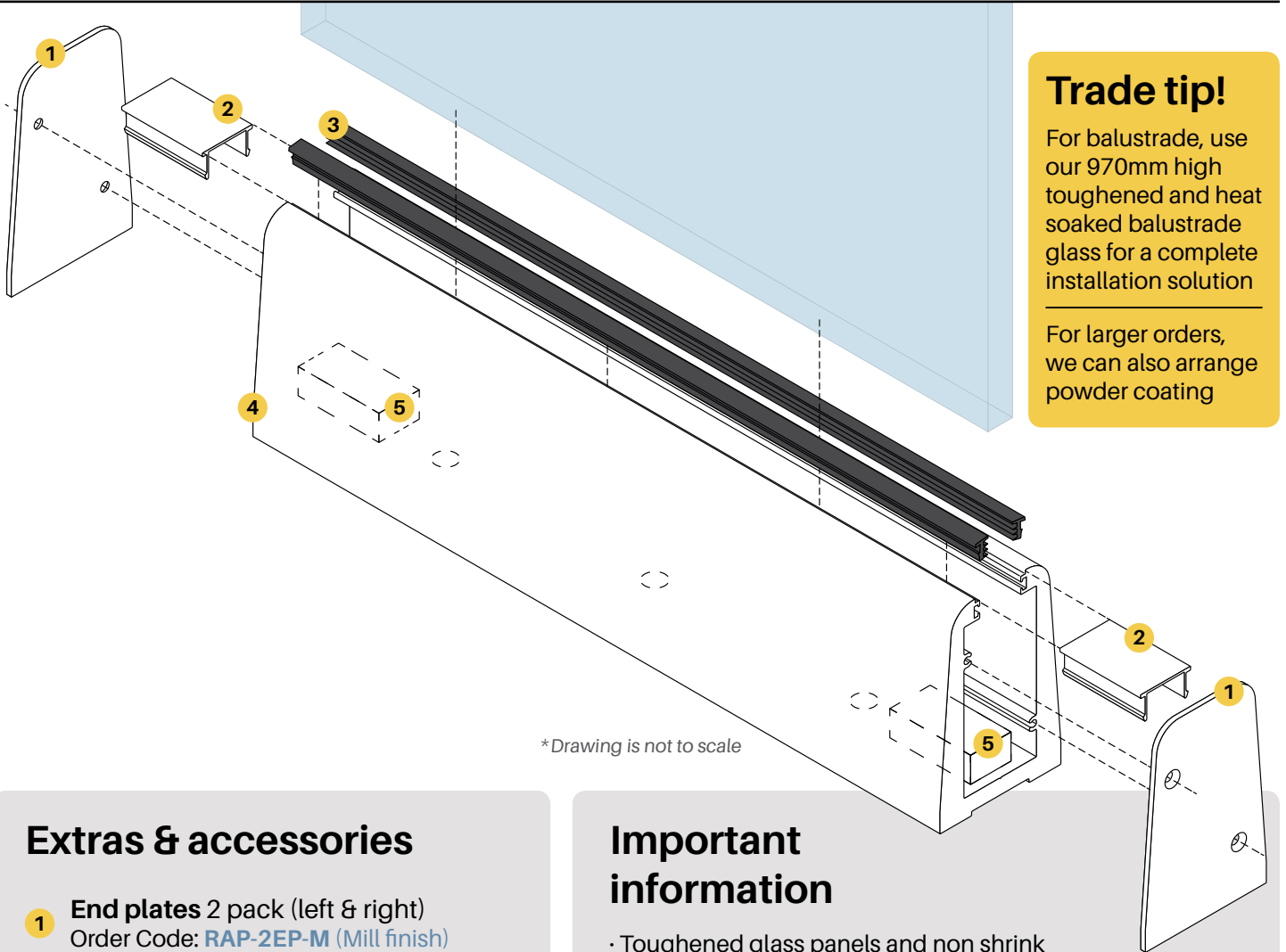

Trade tip!

For balustrade, use our 970mm high toughened and heat soaked balustrade glass for a complete installation solution

For larger orders, we can also arrange powder coating

*Drawing is not to scale

Extras & accessories

- 1 End plates** 2 pack (left & right)
Order Code: [RAP-2EP-M](#) (Mill finish)
- 2 Channel infill** 4200mm long
Order Code: [RAP-4200-INF-M](#) (Mill finish)
- 3 P40 glazing rubber**
Order Code: [A50-P40-ROLL](#)
- 4 Rapid glazing channel**
Order Code: [RAP-4200-CH-M](#) (Mill finish)
- 5 Sitting block** Plastic or rubber
When using 970mm high, minimum 20mm packer required
Not available from Glass Outlet, can be sourced from Clark Rubber or similar

Important information

- Toughened glass panels and non shrink structural grout should always be used when installing
- We suggest fixings with 400mm centres (each installation may be different, please check independent engineering)
- P40 glazing rubber pushes into both side of channel (P40 suits 12mm thick glass. Use suitable rubber for thicker glass)
- Sitting blocks must be high enough to ensure glass does not make contact with fixings
- End caps are affixed by screwing into channel screw flutes with countersunk screws (CSK screws not included)
- Snap-in infill can be used between glass panels. Easily cut infill to required lengths
- Use 15mm socket 3/8 drive (1/2 inch too big)